

Polarimetric Cloud Analysis and Seeding Test 4 (POLCAST4): 2012 Field Season

OPERATIONS PLAN

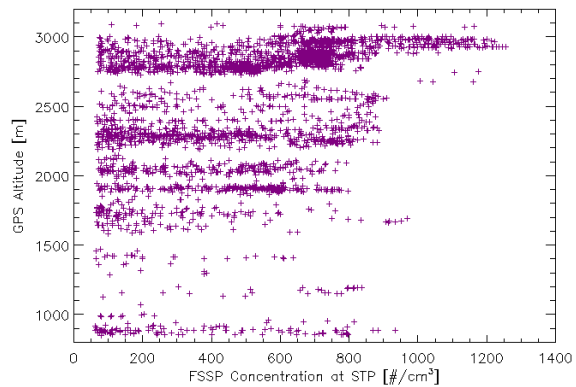
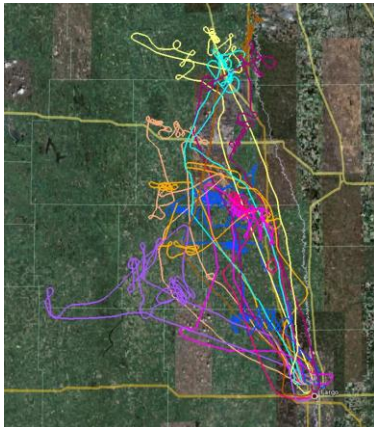
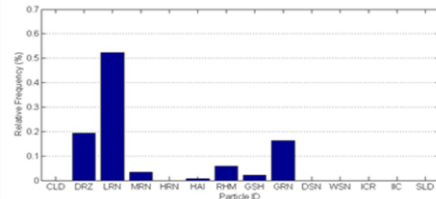
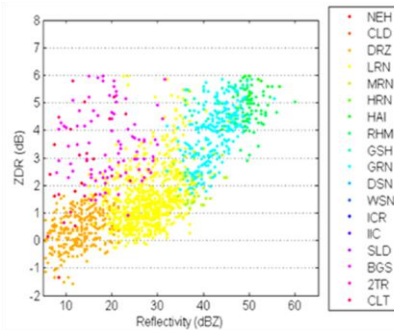
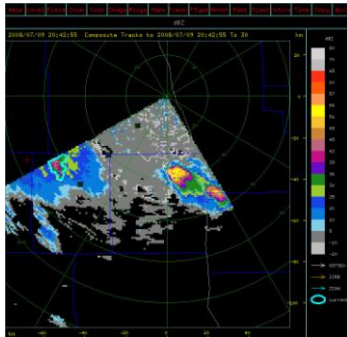

Prepared by:
National Center for Atmospheric Research,
The University of North Dakota, and
The North Dakota Atmospheric Resource Board

Updated: 29 June 2012

Table of Contents

1. Project Objectives	3
2. Institutional Participants	4
3. Area of Study	4
4. Schedule	5
5. Facilities	5
5.1 WMI Cessna 340 Seeding Aircraft	5
UND Polarimetric Radar	6
5.1.1 Radar Specifications	6
5.1.2 Radar Scanning Strategy	8
5.1.3 TITAN Overview	9
5.2 Surface Measurements	10
5.3 UND WRF Modeling	11
6. Project Coordination	12
6.1 Project Management	12
6.1.1 Science Team:	12
6.1.2 UND Student Team:	12
6.2 Project Operations	13
6.2.1 Operations Managers Team:	13
6.3 Forecasting	13
6.3.1 Forecast Team:	13
6.4 Specific Tasks for Day-to-Day Operations	13
6.4.1 Operations Managers Tasks:	14
6.4.2 Daily Project Briefing	14
6.5 Mission Coordinator	15
6.6 Radar Scientist	15
6.7 Aircraft Flight Scientist	15
6.8 Aircraft Flight Engineer	16
6.9 Instrument Technician	16
6.10 Seeding Pilots	16
6.11 Mission Launch Decisions	16
6.12 Suspension Criteria	17
7. Data Management	19
7.1 Aircraft Data	19
7.2 Radar Data	19
7.3 Surface Data	19

7.4	Ancillary Data	19
7.5	WRF Model Output	19
8.	<i>Operational Procedures</i>	20
8.1	Operational Summary	20
8.2	Seeding Aircraft Flight Plan	20
8.2.1	Task A: Characterize the atmospheric conditions before seeding.	20
8.2.2	Task B: Selecting a potential seeding candidate.	21
8.2.3	Task C: Making the seed/no seed decision.	21
8.2.4	Task D: Seeding the cloud.	21
8.3	Surface Measurements Operations	21
8.4	Radar Operations	21
8.4.1	Hydrometeor and Other Scatter Identification	22
9.	<i>References</i>	22
10.	<i>Contact List</i>	23

1. Project Objectives

The Polarimetric Cloud Analysis and Seeding Test 4 (POLCAST4) experiment is a continuation of the original field program that was conducted in the summers of 2006, 2008, and 2010. The 2012 project focuses on a continuation of sampling with the University of North Dakota (UND) polarimetric Doppler weather radar and *in situ* sampling to address the overall project's objective:

- To better understand the effects of hygroscopic cloud seeding at cloud base on convective clouds in North Dakota.

Specifically, POLCAST4 will attempt to:

- Determine identifiable signatures of hygroscopic seeding in polarimetric observables or derived fields;
- Characterization of hygroscopic seeding effects stratified by aerosol and CCN concentrations;
- Characterization of how aerosols and CCN concentration change between the surface and cloud base.

Based on the previous POLCAST studies (e.g., Kucera et al. 2008, Delene et al. 2011) and from the experiences in other studies conducted in the U.S., Saudi Arabia, West Africa, and other regions of the world, we believe that it is extremely important to develop a well-designed field measurement program, making use of the latest technology, to broaden our knowledge of the effects of cloud seeding in the context of the meteorology (e.g., aerosol concentrations, cloud droplet distributions, rainfall climatology, etc.) of the region. Therefore, POLCAST4 will utilize polarimetric radar measurements combined with *in situ* airborne measurements to advance our knowledge of the effects of hygroscopic cloud seeding on convective clouds observed in North Dakota. The operational phase of POLCAST4 focuses on:

- Understanding the natural characteristics of clouds observed in NE North Dakota and their environment;
- Making quantitative measurements (rainfall estimation, liquid water content, raindrop size variations, hydrometeor retrievals) of radar-derived storm properties for assessing potential effects from hygroscopic seeding;
- Determining the time history of such effects and the probable cause, assuming that seeding signatures are detected;
- Testing the concepts of the South African and Mexican hygroscopic seeding approach in Eastern North Dakota;
- Collecting *in situ* measurements that provide substantiation for the physical hypothesis.

2. Institutional Participants

As in the previous field campaigns, POLCAST4 is a cooperative effort between several institutions and is sponsored by the North Dakota Atmospheric Resource Board. The institutions that are a part of POLCAST4 include:

- University of North Dakota (UND)
- National Center for Atmospheric Research (NCAR)
- Weather Modification Incorporated (WMI)
- Ice Crystal Engineering (ICE)
- North Dakota Atmospheric Resource Board (NDARB)

3. Area of Study

The criteria for selecting cases will include that cells will be relatively isolated from surrounding convection and the initial development will be within a maximum range of 100 km (preferably within 50 km) from the radar. Figure 1 shows the location of the maximum sampling range of the UND radar, which is 150 km for high-resolution scanning. Inside the 150 km domain, the study area is indicated by the shaded region. The selected storms must be located in North Dakota when seeded (e.g., west of the Red River). The WMI aircraft will be located in Fargo, North Dakota, which is about 125 km SSE of the UND radar. When atmospheric conditions meet the selection criteria, the aircraft will be launched out of Fargo and directed to the area of interest within the study area. During the surveillance mode, the radar will operate in full volume mode to detect storm initiation over the sample area. When storms of interest are detected in the target area, high temporal (3-5 min) and high spatial resolution, low level sector scans will be utilized until the storm dissipates or moves beyond the 150 km maximum range of the radar. Storms that were seeded in North Dakota will be monitored by radar, and possibly sampled by airborne instruments, even if they move east into Minnesota.

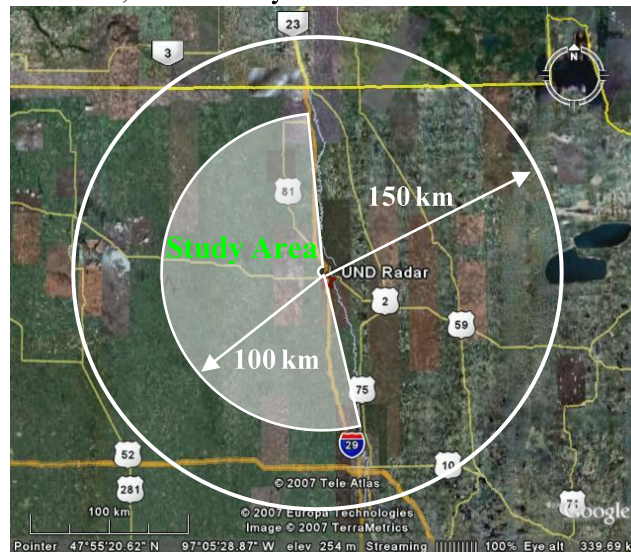

Figure 1: Study area for POLCAST4. The storms will be monitored by radar within the 150 km radius of the UND Radar. Hygroscopic seeding will be conducted within 100 km of the UND Radar, and west of the Red River of the North.

4. Schedule

The intensive operations period (IOP) for POLCAST4 will occur between 27 June – 03 August 2012. Within that time period, there will be a planned break for the 4th of July holiday (3-4 July). A complete list of dates, actions, and participants for the POLCAST4 is given in *Table 1*.

Table 1: Schedule for POLCAST4.

Date	Action	Participants
16 May 2012	Start Instrument Performance Checks	NCAR, UND, NDARB
22 June 2012	Complete Operations Plan	NCAR, UND, NDARB
18-22 June 2012	Aircraft Instrumentation Integration	UND, WMI
25-26 June 2012	Radar Calibration and System Testing	NCAR, UND
27 June 2012	Start of the IOP	NCAR, UND, NDARB, WMI
03-04 July 2012	4th July break – no operations	NCAR, UND, NDARB, WMI
03 August 2012	End of the IOP	NCAR, UND, NDARB, WMI
31 October 2012	Project Summary Report	NCAR, UND
January 2013	Project Meeting/AMS	NCAR, UND, NDARB
April 2013	WMA Meeting	NCAR, UND, NDARB
31 May 2013	Progress Report	NCAR, UND
January 2014	Planning Meeting POLCAST5	NCAR, UND, NDARB
31 May 2014	Final Report	NCAR, UND

5. Facilities

5.1 WMI Cessna 340 Seeding Aircraft

A WMI Cessna 340 aircraft will be used during the project for cloud seeding operations and airborne measurements. The WMI aircraft will be equipped with flare racks that are compatible with the hygroscopic flares manufactured by Ice Crystal Engineering. The WMI aircraft will be instrumented with a Science Engineering Associates (SEA) model M300 data system, a Passive Cavity Aerosol Spectrometer Probe with SPP200 electronics upgrade package (PCASP) a University of Wyoming (UWyo) Cloud Concentration Nuclei Counter (CCNC), a Droplet Measurement Technology (DMT) CCNC, AINMMS-20 probe, and a Forward Scattering Spectrometer Probe (FSSP) with SPP100 electronics upgrade package.. The PCASP and CCNCs will be used to characterize the cloud base aerosols. The PCASP measures the aerosol size distribution from 0.1 to 3 μm and the CCNCs measures the concentration of aerosols that form cloud droplets at a certain supersaturation. The UWyo CCNC will be operated at a single supersaturation of 1 % (counter set supersaturation which gives an ambient supersaturation of 0.6 %). The DMT CCNC will be operated at 0.2, 0.3 and 0.6 % ambient supersaturation. Table 2 provides a list of the WMI Cessna 340 aircraft equipment for POLCAST4, with detailed information provide on the POLCAST4 Wiki (<http://atmoswiki.aero.und.edu/atmos/citation/field/northdakota2012/home>). Performance checks will be conducted on the airborne and surface instrument before, during and after the field project, including performance checks on the CCN counters.

Table 2: A summary of WMI Cessna 340 equipment for POLCAST4.

Instrument	Owner	Location
Rosemount 102AU1AP	WMI	Wing – Bottom
PCASP-SPP200	WMI	Wing – PMS Can
SEA M300 Data System	WMI	Inside Cabin
SEA Analog/Digital Board	WMI	Inside Cabin
University of Wyoming CCN Counter	NCAR RAL	Inside Cabin
Droplet Measurement Technology CCN Counter	WMI	Inside Cabin
Static Pressure Transducer	WMI	Co-Pilot
IAS Pressure Transducer	WMI	Co-Pilot
VHF Telemetry System	WMI	Bottom

POLCAST4 Lab: Cloud Condensation Nuclei Performance Check

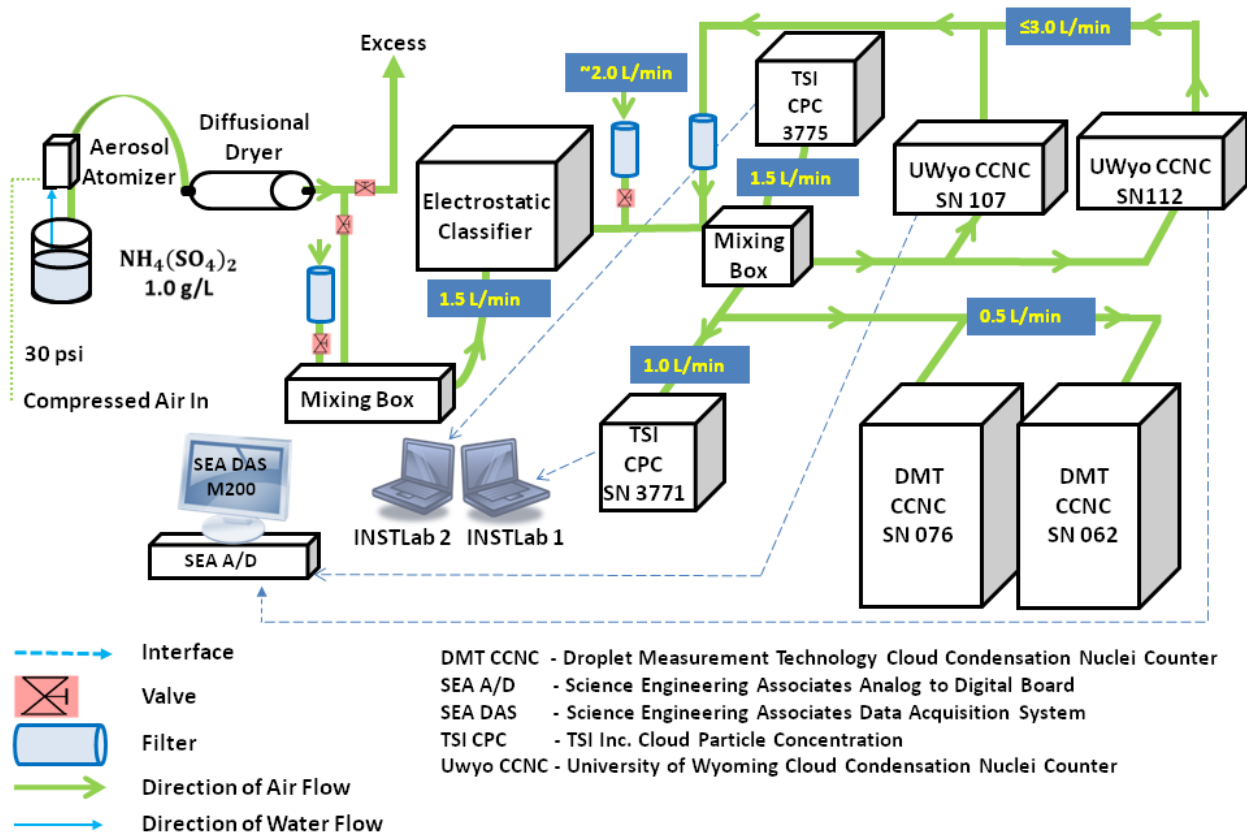

Figure 2: Laboratory configuration used to conduct performance checks on the Cloud Condensation Nuclei Counters.

UND Polarimetric Radar

5.1.1 Radar Specifications

The UND radar is located on top of Clifford Hall, which is located on the west side of the University of North Dakota campus in Grand Forks, North Dakota. The coordinates of the UND

radar are: $47^{\circ} 55' 19''$ N latitude and $-97^{\circ} 5' 11''$ W longitude. The Department of Atmospheric Sciences upgraded the UND C-band (5 cm wavelength) Doppler radar (see Fig. 3) to have polarimetric capability in January 2004. The original components of the UND radar were built by Enterprise Electronics Corporation (model: Weather Surveillance Radar - 1974 C-band: WSR-74C). In January 2003, the radar was upgraded with a SIGMET, Inc. (<http://www.sigmet.com>) digital receiver and signal processor (RVP8), radar antenna controller (RCP8), radar control, analysis and display software (IRIS). In January 2004, the radar was upgraded to a dual-polarized antenna mounted receiver (AMR) system. The UND radar (called NorthPol) operates in support of the research and academic programs. Table 3 provides a summary of the UND radar specifications. A more complete description of the UND polarimetric Doppler radar along with access to quick-look radar products can be found at the radar website: <http://radar.atmos.und.edu>.

The radar can be operated remotely using IRIS networking configuration. During operations, the UND radar (and radio communications) will be monitored in the Operations Center located on the 6th floor of Clifford Hall. Data are collected by the IRIS workstation (radar1) located in the Operations Center and then are sent to the IRIS archive, product generation, and display workstation (radar2) located in the Atmospheric Sciences computer room located on the 4th floor of Clifford Hall (Computer Lab). Data will be archived on RAID5 large disk array and backed up on a USB portable hard drive located on radar2 to minimize the possibility of data being lost. A variety of products and the real time display will be available to scientists and visitors during POLCAST4 on a variety of IRIS Display systems that are networked throughout the Atmospheric Sciences Department.



Figure 3: An image of the UND radar antenna located on top of Clifford Hall (foreground) on the University of North Dakota campus in Grand Forks, ND.

Table 3: Technical Specification of the UND C Band Radar.

Radar Parameter	Value
Peak Output Power (kW)	250
Wavelength (cm)	5.4
Pulse Width (microsecond)	0.6, 2.0
Antenna Gain (dB)	43.75
Elevation Range (°)	-0.5 – 90
Antenna Height Above Ground (m)	28
Beam Width (degree)	0.99
Minimum Detectable Signal (dBm)	-114
Maximum Scan Speed (°/sec)	20
PRF (Hz)	250-1200
Polarization	Linear Horizontal and Vertical
Variables	ZH, VR, σ , ZDR, KDP, Φ DP, ρ HV
Data System	SIGMET IRIS

5.1.2 Radar Scanning Strategy

The UND radar will be operated in high-resolution scanning mode during POLCAST4. During routine surveillance, the radar will scan in a full-volume mode (e.g., 16 tilts with a maximum elevation angle of $\sim 22^\circ$) to a maximum range of 150 km. The spatial resolution of the polarimetric fields will be 250 m with a temporal resolution of 10 min. When a candidate case is within the 100 km range of the radar and is of interest for the study, the radar scanning will be switched to 1-3 min sector scan mode centered on the candidate case. The sector scan will have the vertical resolution as the full-volume scan at the lowest elevation tilts (elevation of $\sim 5^\circ$) to ensure adequate sampling at low levels and provide high temporal resolution to capture the temporal evolution of the storms. Table 4 shows a summary of the characteristics of the scanning strategy. Figure 4 shows a visual summary of the elevation angles that will be used during POLCAST4.

Table 4: Proposed POLCAST4 scanning strategies for the UND Radar.

Volume Scan Mode	Sector Scan Mode
Gate Spacing = 250 m, PRF = 1000	Gate Spacing = 250 m, PRF = 1000
Azimuth Limits = 360° , Azm Res = 1°	Azimuth limits = 30° - 90° , Azm Res = 1°
Scan Rate = 10° s^{-1} , Pulse Width = 0.6 μs	Scan Rate: 8° s^{-1} , Pulse Width = 0.6 μs
Repeat Time = 10 min	Repeat Time = 1-3 min
Elevation Angles (deg) = 0.49, 1.44, 2.38, 3.33, 4.27, 5.22, 6.16, 7.11, 8.05, 9.9, 11.8, 13.7, 15.5, 17.4, 19.0, 22.0	Elevation Angles (deg) = 0.49, 1.44, 2.38, 3.33, 4.27, 5.22
Observables: dBZ, dBZ _T , VR, SW, ZDR, PhiDP, KDP, RhoHV	Observables: dBZ, dBZ _T , VR, SW, ZDR, PhiDP, KDP, RhoHV

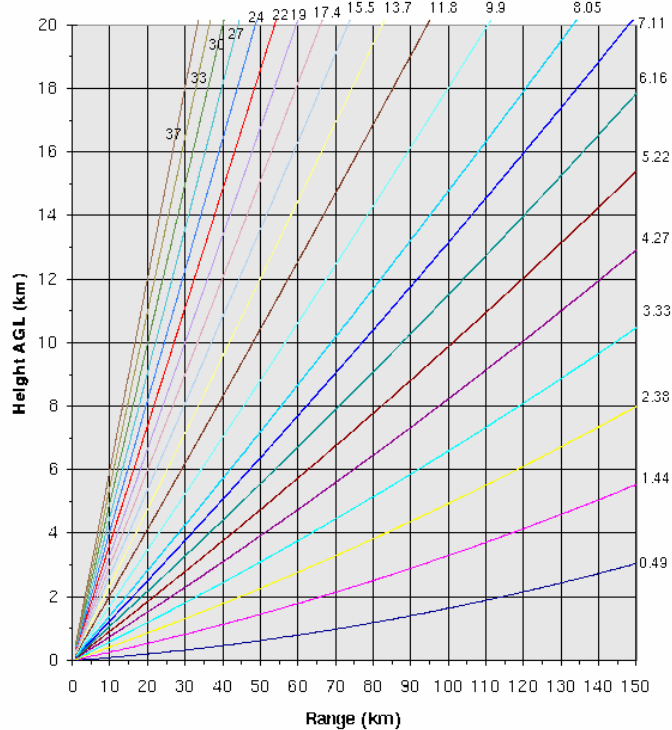

Figure 4: Range height diagram showing the location of possible elevation angles used in POLCAST4. We plan to use a reduced number of elevation angles (maximum 22° for volume scan and 5.2° for sector scans) to increase temporal resolution.

5.1.3 TITAN Overview

The radar processing and display system is called TITAN (Thunderstorm Identification, Tracking, Analysis, and Nowcasting) and is described by Dixon and Weiner (1993). In addition to TITAN, a newer Configurable Interactive Data Display (CIDD) system has also been installed on a high performance Linux workstation that is located next to the operations IRIS display in the radar operations room on the 6th floor in Clifford Hall. The TITAN Rview program displays radar data and aircraft position in real-time for the purpose of directing the operations. A VHF antenna with data radio is used to provide TITAN with flight track information from the seeding aircraft. The CIDD system is routinely set to display an animated 1-hour movie loop of the high resolution polar radar data. The TITAN system archives the processed data to disk. A backup copy will be made to an external USB hard drive. The TITAN system has the following main functions:

- ***Ingests radar data (sigmet2DSR)***
- ***Pre-process and stores data***
- ***Run algorithms on data***
- ***Display data and algorithm output***
- ***Provide post analysis capabilities***

The radar data are first displayed using a multi-color code that corresponds to contoured reflectivity values. The data are then manipulated and can be displayed in many different ways. Some of TITAN's display and analysis capabilities are listed below.

- *PPI (Plan Position Indicator) is a 2 dimensional, composite display of the radar echo over the area covered.*
- *RHI (Range Height Indicator) is used to view a cross section of a portion of the storm.*
- *Aircraft flight track display capability*
- *History of storm motion and intensity display*
- *Projected storm motion display*
- *Precipitation mapping*
-

5.2 Surface Measurements

The objective of the surface measurements is to put the cloud base aerosol measurements in context (how similar/different are the cloud base and surface measurements) and to determine the conditions under which surface aerosol measurements can be used to infer cloud base aerosol properties. The surface measurements (Figure 5) will include precipitation rate (NCAR Video Disdrometer), cloud condensation nuclei (WMI UWyo CCN Counter and WMI DMT CCN Counter), aerosol size spectrum from 0.1 to 3.0 μm (UND Passive Cavity Spectrometer Probe), and condensation nuclei concentration (UND TSI CPC 3771). In addition to these instruments, for part of the project particulate matter less than 2.5 μm (UND High Volume Filter Sampler and UND Tapered Element Oscillating Microbalance) and the aerosol size spectrum (TSI Scanning Mobility Particle Sizer) will be made. These instruments will be deployed on the roof of Clifford Hall on the University of North Dakota's campus in Grand Forks. The instruments will be set up and configured to run continuously during the aircraft measurement program. The UWyo cloud condensation nuclei counter pads dry out after approximately an hour of operations (Delene and Deshler, 2000) so only measurements when personnel are normally around will be valid. Laptops and a SEA M200 data system will be used to collect the surface measurements and data will be processed and analyzed using the Airborne Data Processing and Analysis Software package (Delene, 2011).

POLCAST4 Surface Measurements: Clifford Hall 601

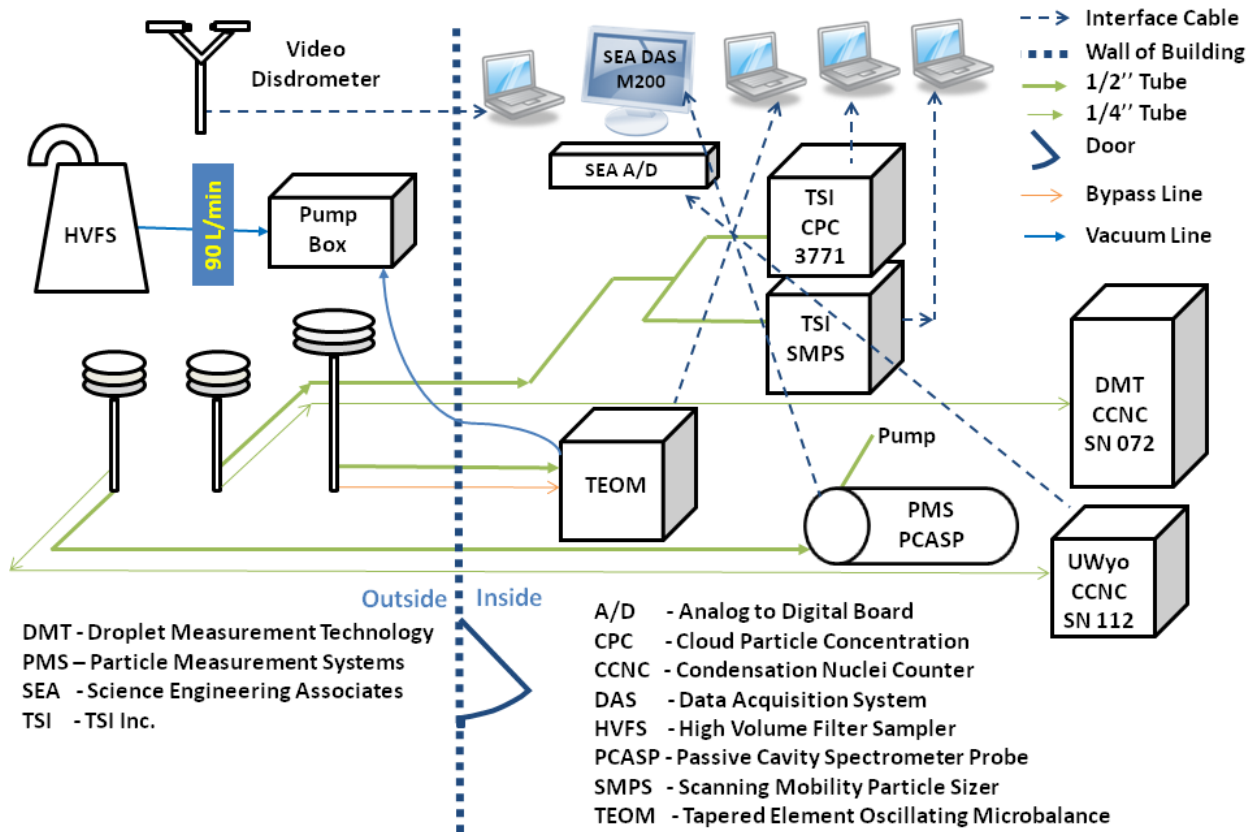

Figure 5. Diagram of how instruments will be setup for conducting surface measurement on the top of Clifford Hall.

5.3 UND WRF Modeling

The UND forecast runs twice daily from the NAM 212 domain 00 UTC and 12 UTC forecast output. The local 36-hour forecast, which runs in WRF-ARW (v. 3.1.1), starts at 2150 and 0950 local time and completes at approximately 0900 and 2100 local time, respectively. The forecast runs 3 domains with horizontal domain spacing of 27, 9, and 3 km, and 45 vertical levels (vertical grid stretched). The innermost nested domain represents the forecast area for the Grand Forks NWS WFO with a greater northern extent to capture the full NorthPol coverage area. Output is saved at 3-hour intervals for the 27- and 9-km domains and at 1-hour intervals for the 3 km domain.

Model physics:

- Microphysics: WSM 6-class graupel scheme
- Radiation: RRTM, Dudhia (dt = 30 min)
- Land-surface model: unified Noah LSM
- Surface layer: Monin-Obukhov scheme
- Boundary layer: YSU scheme

- Cumulus: Kain-Fritsch (new Eta) scheme (27 and 9 km domains); no parameterization for 3 km domain

A variety of forecast products are being generated to support the project. Some of the products include, but are not limited to: gridded surface temperature, sea-level pressure, and horizontal wind vectors; forecast sounding for the Grand Forks Airport; gridded reflectivity field; gridded total precipitation field; and gridded relative humidity and wind vectors at 850 mb fields. The latest model output can be viewed online at the website:

<http://people.aero.und.edu/~gretchen/forecast/>

6. Project Coordination

The success of a field project depends on close coordination of personnel involved at the different facilities (forecast office, radar facility, and aircraft facility). The key functions of personnel involved in the project are briefly described in this section. Some functions may be shared between personnel. Typically, one person will be responsible for a particular function and a second person may fill in for a time when necessary.

There are numerous components to this field project, including forecasting and operational decision making, performing the physical studies, performing the seeding missions, maintaining the instrumentation, managing and archiving data, and doing data post-processing. Good coordination between UND, WMI, NCAR, and NDARB are essential for the success of this project.

6.1 Project Management

The overall coordination of the organizational and logistical issues of POLCAST4 will be the responsibility of NDARB Director, Darin Langerud. The overall project scientific manager will coordinate with the operations managers to achieve the research objectives.

6.1.1 Science Team:

- Paul Kucera (NCAR)
- David Delene, Chris Thiesen, Gretchen Mullendore, Students (UND)
- Darin Langerud, (NDARB)

6.1.2 UND Student Team:

- Mariusz Starzec (WRF Modeling, Radar)
- Nicholas Carletta (WRF Modeling)
- Nicole Bart (Aircraft, Surface Measurements)
- Phondie Simelane (Surface, Aircraft Measurements)
- Timm Uhlmann (Radar)

6.2 Project Operations

Responsible for the day-to-day direction of routine operations, logistics, tracking of facilities status, support to facilities operations and maintenance, support to project personnel, and other tasks.

6.2.1 Operations Managers Team:

- Paul Kucera (NCAR) – Radar Operations
- David Delene (UND) – Airborne and Surface Measurements
- Hans Ahlness (WMI) – Aircraft Operations

6.3 Forecasting

Forecasts for the development of convection, particularly over the 24 to 48 hour range will be generated during the project. The forecast function will be led by staff at NDARB. The forecast staff will be responsible for a daily forecast briefing and gathering all related forecast products and observations (NWP forecasts, UND WRF, soundings, satellite observation, etc.). The daily forecast and selected meteorological data will be posted to the project website. The website will be maintained by NDARB and will be found at <http://www.swc.nd.gov/arb/>. Access to the site will require a login and password, which will be provided to all POLCAST4 personnel.

6.3.1 Forecast Team:

- Dan Brothers (NDARB)

6.4 Specific Tasks for Day-to-Day Operations

The operations direction will be conducted from the UND Atmospheric Sciences Department. The operations managers coordinate the day-to-day operations and personnel involved in the operations. This involves the overall management of all the field program activities including radar and aircraft operations. The operation managers will be responsible for scheduling all operations and will take into consideration all available meteorological data and weather forecasts and will classify the day into one of the categories listed in *Table 5*.

Table 5: The daily code and team readiness based upon potential for significant convection and where it will be located.

Code	% Chance of Seedable Clouds	Comment	Team Readiness
Red	70 – 100 %	High likelihood of convection	Radar and aircraft teams on station standing by for operations
Yellow	40 – 70 %	Good chance of convection	Radar and aircraft teams on station standing by for operations
Green	15 – 40 %	Small chance of Convection	Teams on standby by phone or email
Blue	0 – 15 %	No chance of Convection	Stand down

6.4.1 Operations Managers Tasks:

- Helps coordinate the daily weather briefing (including weekends) at 1000 (Central Time).
- Scheduling all operations for the current and next day.
- Update next day's morning status by 1800 (Central Time) if morning operations are possible.
- Decide operational status based on forecast and aircraft readiness.
- Update all personnel on planned operations for the day.
- Notify all team members when they may stand down for the day.

6.4.2 Daily Project Briefing

A daily project briefing will be conducted each day of field operation that starts at 1000 (Central Time). All project personnel are invited to attend the daily briefing which will be conducted via teleconference so personnel from locations (Grand Forks, Fargo, Bismarck) can take part. The 6 person teleconference bridge number is 701-777-0967 and the access code is 528784. UND personnel will meet in Clifford Hall 422 and access the teleconference via a speaker-phone. A contact list with phone numbers and email addresses will be created and distributed before the start of field operations so personnel can contact one another outside of the daily briefing. The daily briefing will proceed in the following manner:

- Weather Forecast
 - Current conditions and forecast for current day's operations.
 - Forecast for tomorrow and outlook for the next few days.
 - Questions concerning the weather and forecast.
- Equipment Status
 - Aircraft
 - Aircraft Instruments
 - Radar
 - Surface Instruments
- Define Operations for the Day
 - Define personnel responsible for Mission Operations (If necessary).
 - Designating a down day (~ 24 hours or more in advance) based upon forecast information, overall needs of the project, and overall personnel needs for rest time.
- Review of previous mission (If necessary)
 - Aircraft Flight Overview

- Airborne Measurements Overview
- Radar Measurements Overview

6.5 Mission Coordinator

A Mission Coordinator (Paul Kucera, Chris Theisen, and/or students) will monitor the radar for signs of convective activity during aircraft operations and provide guidance on conditions to the aircraft as well as communicating operational decisions (areas to fly to, type of mission, etc.). The Mission Coordinator will utilize his/her training in operating IRIS and interpreting the radar real time display and products to direct aircraft to potential candidate clouds during seeding operations.

6.6 Radar Scientist

A Radar Scientist (Paul Kucera, Chris Theisen, and/or students) will be available to monitor the radar for signs of convective activity and other targets of opportunity. The Aircraft Coordinator may often fill this role. However, having two people to direct the aircraft and operate the radar will be beneficial for coordinated radar-aircraft operations. Familiarity with polarimetric radar operations, scan strategies for different missions, and operation of the various radar display programs in IRIS is important. The radar scientist continually monitors progress of the current radar objective/mission and anticipates the options for the next mission. During periods of expected activity, it is recommended that the radar display be checked on a regular basis (approximately every 20 minutes) when waiting for the onset of storms. Specific duties of the radar scientist include:

- Keeping a rigorous watch on the radar during times when convection is expected to form (daytime hours) or assign someone to do so.
- Updating the aircraft scientist of expected convection.
- Notifying the Operations Director (Paul Kucera or David Delene) or Aircraft Coordinator (David Delene) of location and intensity when activity commences.
- Writing a radar operations summary.
- Performing a debriefing of radar activity.

6.7 Aircraft Flight Scientist

An Aircraft Seeder Flight Scientist on the WMI aircraft (David Delene (lead)) will accompany all flights unless the aircraft scientist is not available before the scheduled departure of the aircraft. The specific duties of the Aircraft Flight Scientist include:

- Determining the practicality of performing physical studies in coordination with the radar scientists and pilots.
- Determining appropriate physical studies and corresponding flight plans.
- Requesting feedback from the pilots regarding feasibility of performing desired flight patterns.
- Documenting flight activities while onboard the aircraft.
- Assisting the Instrumentation Technician in instrument preparation prior to flight

- Monitoring the data acquisition system and instruments during the flight and reporting the instrument status to the Operations Managers and Instrument Technician.

6.8 Aircraft Flight Engineer

The Aircraft Flight Engineer (David Delene, student) will be responsible to ensure that instruments are functioning and obtaining valuable data. The Aircraft Flight Engineer will perform quality control checks (calibration checks) on the aircraft instruments (e.g. PCASP, CCN Counters) throughout the project. The Aircraft Flight Engineer will also perform data quality assurance on the data set after each flight and report any potential problems to the Flight Scientist. Particular instrument responsibilities for each Aircraft Flight Engineer are:

- David Delene - Overall responsibility for all instruments.

6.9 Instrument Technician

An aircraft Instrument Technician (Dennis Afseth for Seeding Aircraft) will be present to maintain instruments on the aircraft. The Instrument Technician may assist in preparation of aircraft prior to flight and will work closely with the Aircraft Flight Scientist to ensure that the instruments are working properly. The specific responsibilities of the Instrument Technician include:

- Preparing instruments prior to flight.
- Maintaining instrumentation records.
- Provide all calibration records to Science Team.
- Assisting the aircraft mechanic in maintaining the aircraft in operating condition.

6.10 Seeding Pilots

During the aircraft seeding flights, the lead pilot (Hans Ahlness) will do the cloud selection, which includes identifying suitable clouds, flying continuously in updraft regions, and making decisions on seeding/sampling operations according to the Experimental Design. More specific responsibilities of the Seeding Pilots may include:

- Assisting the operation managers in formulating flight plans for the day
- Filing summary reports on operations.
- Assisting the aircraft mechanic in maintaining the aircraft in operating condition, including changing flares, reporting problems immediately, and helping troubleshoot problems.
- If no flight scientist is on-board, turning on the aircraft data acquisition system and verifying all on-board instrumentation is working properly.
- Selecting seeding candidates and declaring cases in consultation with the radar and flight scientist.
- Performing a debriefing of the flight.

6.11 Mission Launch Decisions

The Operations Managers Team will decide to call for the aircraft to launch when visual observations, radar echoes and/or nowcast conditions suggest a high likelihood of finding

suitable cases, for study or for seeding. The WMI pilot will file a flight plan and advise the necessary WMI personnel to ready the aircraft for launch. The Aircraft Flight Scientist will relocate to Fargo. A final launch check (via phone call to Operation Center) will be conducted just prior to personnel (Pilot, Flight Scientist) entering the aircraft for engine start.

Physical studies and seeding will only be conducted during daylight hours. There will be no operations scheduled for the 4th of July holiday (3-4 July). The Operations Managers Team will coordinate and determine days for crew rest and will attempt to schedule these on clear days.

6.12 Suspension Criteria

Seeding suspension criteria have been developed, reviewed, revised, and employed in the NDCMP since the Board’s creation in 1975 (see Orville *et al.* 2003). Generally termed “safeguards”, these criteria are designed to avoid treatments of any storm that might pose a flood or tornado threat. In some cases, seeding may be suspended to avoid even the appearance of possibly hazardous activity.

The seeding suspension criteria are shown in Table 6, and the methodology whereby flood potential is evaluated is shown in Fig. 4. The importance of taking prompt action when suspension criteria are met ***cannot be overemphasized***. If the Mission Coordinator has any doubt about whether suspension criteria are met, he or she should order seeding stopped, and then contact the ARB Director for clarification. While the ARB Director should be notified when seeding activities are suspended, the first action taken must be to stop the seeding.

Table 6: Seeding Suspension Criteria.

<p>1.</p> <p style="padding-left: 40px;">A.</p> <p style="padding-left: 40px;">B.</p> <p style="padding-left: 40px;">C.</p> <p style="padding-left: 40px;">D.</p> <p>2.</p> <p>3.</p> <p>4.</p> <p>5.</p>	<p><i>Tornado or funnel-bearing clouds will not be seeded. The trigger for suspension can come from two situations; NWS Tornado Warning, or observation by project personnel.</i></p> <p><i>If seeding is in progress, it will be terminated upon issuance of NWS Tornado Warning or funnel/tornado sighting by project personnel.</i></p> <p><i>The nearest project aircraft will be sent to confirm the warning if possible. If it cannot be confirmed, seeding can resume immediately. If the tornado/funnel is confirmed, proceed to step C below.</i></p> <p><i>Seeding will not resume until 30 minutes have elapsed after the funnel or tornado dissipates. Efforts will be made to report all tornado or funnel sightings by project personnel to the appropriate NWS office as soon as it can be safely accomplished.</i></p> <p><i>Seeding will cease on issuance of a NWS Tornado Warning at night until the warning has expired or been cancelled.</i></p> <p><i>Stationary storms producing rainfall in excess of 2 inches/hour will not be seeded. (Reflectivities greater than 54.5 dBZ).</i></p> <p><i>No seeding will be done on any storms with flood potential according to Fig 33.</i></p> <p><i>Seeding will cease in a region under a NWS flash flood warning until warning is cancelled.</i></p> <p><i>Seeding will cease upon request of the local weather modification authority, as relayed through</i></p>
--	--

the Director or the Chief Meteorologist

6. *Seeding will cease whenever the field meteorologist determines that a potential flash flood situation exists.*

FLOOD POTENTIAL

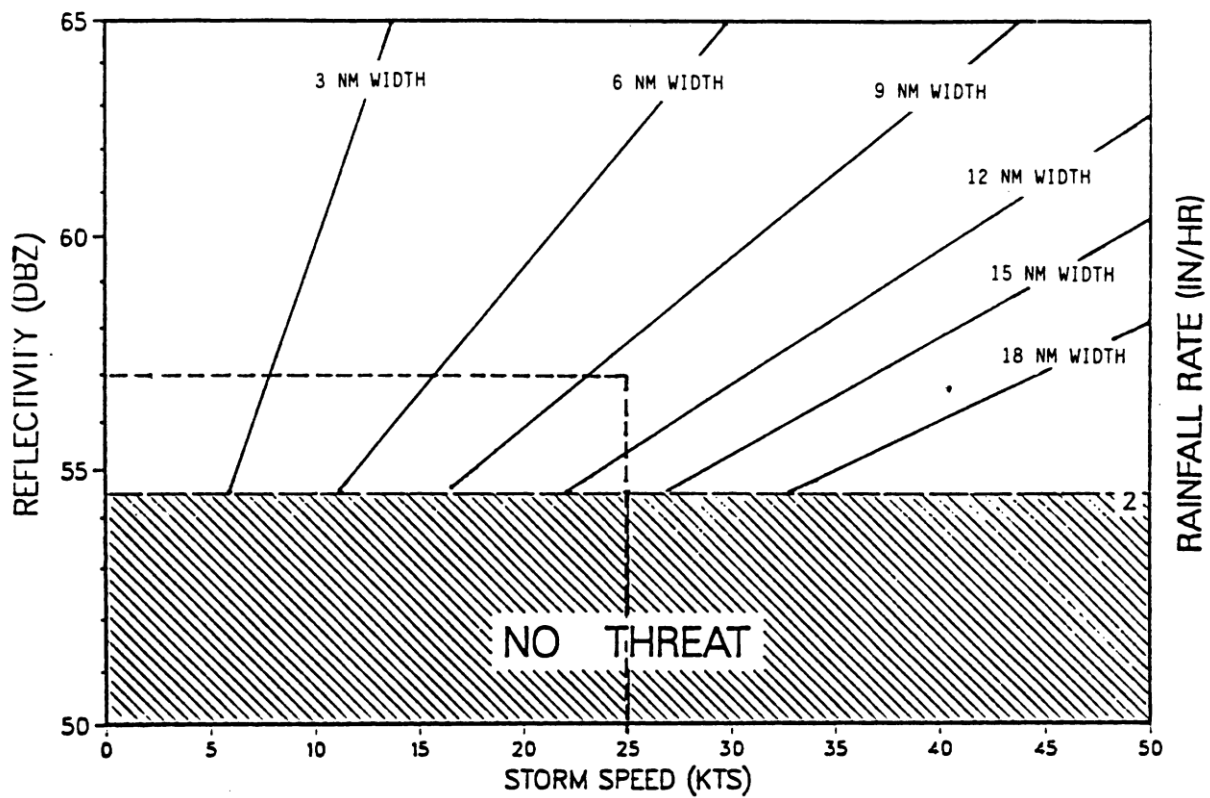

Figure 4: Flood potential assessment graph, utilizing radar reflectivity, speed of cell movement, and width of the heavy precipitation core.

7. Data Management

Overall data management will be a coordinated effort between the personnel from the different institutions. The majority of data and documentation archival will be the responsibility of scientists involved with the instrumentation. There will be several types of data acquired in the field including: aircraft, radar, upper air soundings, automated weather station data, synoptic overviews, surface observations from the surface site and WRF model forecasts. All data will need to be monitored for proper collection and archival. A project Wiki page (<http://atmoswiki.aero.und.edu/atmos/citation/field/northdakota2012/home>) will be used to organize project documentation (e.g. calibration documentation, calibration check results, aircraft instrument status, how to information, Web links).

7.1 Aircraft Data

Aircraft data will be recorded on a data acquisition system (M300) and transferred to ground based computers for post-flight processing and archival. The Aircraft Flight Scientist (David Delene) will be responsible for copying the flight data (*.sea file) to the data card.

7.2 Radar Data

Radar data will be archived on the UND radar archive workstation. Only the raw data will be stored as products can be regenerated from the raw product. Data will also be backed up on a USB drive. The radar scientist (Paul Kucera) will be responsible for proper archiving of the radar data.

7.3 Surface Data

Surface data will be collected on laptops and a M200 located on the top floor of Clifford Hall. M200 data will be recorded on 8 mm tapes and transferred to the Lightning computer server and a shared network drive (NAS) during each day of operations.

7.4 Ancillary Data

Ancillary data (soundings, satellite imagery, weather charts) that will be useful when analyzing the flight missions will be archived locally at UND during the project by using scripts to automatically retrieve images and data from the Internet. The Plume (<http://plume.atmos.und.edu>) server will be used to archiving ancillary data.

7.5 WRF Model Output

WRF model output will be archived using the Plume server:
http://plume.atmos.und.edu/wrf_polcast4_plume

All data raw model output data will be saved to enable additional model products to be created after the conclusion of the project.

8. Operational Procedures

8.1 Operational Summary

In summary, POLCAST4 provides a unique opportunity to validate physical chain of events of the hygroscopic seeding conceptual models through the ability to seed and measure storms at the same time, to document microphysical characteristics, and monitor the development remotely using polarimetric radar to examine the hygroscopic seeding signatures. Concurrent physical measurements with the seeding experiment could help scientists to either confirm or discard aspects of the seeding conceptual model and strengthen any statistical results from a more extensive randomized seeding experiment. Aircraft operations are emphasized here. Radar operations in general will focus on documenting the variability and range of radar responses (e.g., traditional and polarimetric signatures) to natural precipitation development, the area of which is unconstrained outside the area of aircraft operations.

On days with a moderate to good chance of convection in the study area, the WMI pilot will be put on standby for a possible flight(s). If the chances are likely for a mission, the flight scientist will relocate to Fargo. Once convection is observed in the study area, the pilot and/or aircraft flight scientist will be contacted to coordinate the launch and vectoring of the aircraft to the initial location. Once the aircraft is airborne, the Operations Center will relay an update on the location of possible targets. The aircraft will transit to the location as directed by the Operations Center visually looking for possible targets along the flight path. If a cloud looks like a suitable candidate (a new, growing isolated cell: e.g., rain free cloud base, visually growing cloud tops, the cloud diameter $> \sim 5$ km in diameter), the aircraft will investigate by flying underneath looking for suitable conditions (see next Sec 8.2, Task B for condition criteria). The pilot and flight scientist will coordinate the flight path to investigate for suitable targets. If a suitable seeding case is declared by the flight scientist and pilot, the pilot will communicate with the Operations Center that they declared a suitable target. The Mission Director or Radar Scientist will open the envelope with the seeding decision and communicate the target decision (seed/no seed) to the aircraft. Once a case has been declared, the aircraft will communicate general information regarding the case (e.g., start/stop of flares, cloud conditions, etc.). Once a case is complete (once seeding/and or sampling for both seeded/no seeded cases has finished), the Operations Center will update the aircraft with the location of any additional possible targets. The aircraft may also choose to remain in the area if other clouds look suitable for the study.

The main scientific objective of the POLCAST4 is to conduct a randomized seeding experiment. To support this objective, the Cessna 340 aircraft operated by WMI will conduct randomized seeding for high priority targets and take aerosol measurements in and around the clouds being studied. The aircraft should be launched early when conditions are forecast to be favorable for such high priority targets. The aircraft will not conduct seeding unless it is a randomized seeding experiment case.

8.2 Seeding Aircraft Flight Plan

8.2.1 Task A: Characterize the atmospheric conditions before seeding.

The aircraft will take off from Fargo and climb to at least cloud base altitude.

8.2.2 Task B: Selecting a potential seeding candidate.

Upon arriving at the target area, the aircraft will descend to cloud base (if necessary) and begin looking for a suitable case. The desirable characteristics are evidence of growth in the early stages of development and an updraft velocity at cloud base of at least 500 ft/min. The cloud base temperature should be between 4 °C and 20 °C. Precipitating clouds will not be selected. Ideally, clouds will be selected that are isolated in nature; however non-precipitating feeder cells in a flanking line of mature convection may also be targeted.

8.2.3 Task C: Making the seed/no seed decision.

Upon deciding on a seeding candidate, the flight scientist will talk to the operation center and the decision on whether to seed or not to seed will be relayed to the aircraft. A set of seed/ no seed decisions will have been compiled prior to the start of the program and will be kept at the operation center. The decisions will be kept secret and opened one at a time as they are needed.

8.2.4 Task D: Seeding the cloud.

Upon receiving the randomization decision, the aircraft will circle in the updraft, which should be at least 500 ft/min, seeding or not seeding as the randomization decision dictates. The aircraft will burn a total of 8 flares per cloud, two at a time. As each flare burns for approximately 3 minutes, this should take approximately 12 minutes. A new set of flares should be started as soon as the previous set of flares starts to show signs of burning out. If the decision is no seed and it is the first case (see below), the aircraft will ascend and sample the cloud. Note, any comparisons between seeded/no seed cases will be done with data collected after 12 minutes from decision time. If the cloud is not the first case, the aircraft will still circle in the updraft for 12 minutes prior to ending the case. At this time, it will be determined whether or not there are other candidate clouds in the area. If there are, the aircraft will proceed to the next potential seeding candidate after the study of the case is complete.

8.3 Surface Measurements Operations

Surface measurements will be made starting after the 10 am project briefing and continue until after the seeding aircraft has landed. The CCN counter baseline voltage will be checked every 15 minute to ensure that the top and bottom pads do not dry out.

8.4 Radar Operations

A complete radar system calibration, which includes receiver, power, and frequency checks, will be conducted before and after the field phase. Weekly sun calibrations and internal receiver calibrations will be conducted throughout the field phase to ensure consistent data quality. We propose the use of the UND radar to:

- Collect information on natural and seeded cloud and precipitation characteristics
- Help direct the operations with the cloud physics and seeding aircraft
- Provide general information to the weather forecast personnel
- The following paragraphs describe in more detail the different aspects of the radar analysis capability with the advanced radars available to the program. The POLCAST

projects are only a few studies in the history of weather modification experiments that such measurements (e.g., polarimetric radar and aircraft) will be available for the assessment and evaluation of the effects of cloud seeding on rainfall.

8.4.1 Hydrometeor and Other Scatter Identification

Dual-polarization measurements are very useful for identifying internal characteristics of storms by the added polarimetric information (Bringi and Chandraseker 2001). This is useful for data quality activities and identifying the characteristics of the precipitation. Permanent and anomalous propagation ground clutter can be identified and removed. Birds and insects can be identified and thus not mistaken for precipitation.

Polarimetric radars transmit and receive both horizontally and vertically polarized radiation, providing more information about the scattering media than conventional radars. The measurements depend on the microphysical characteristics of hydrometeors; namely:

- Particle size
- Particle shape
- Particle orientation relative to the local vertical direction
- Phase (liquid or ice)
- Bulk density (wet, dry, aggregate, or rimed)

The information is used with “fuzzy logic” technique (NCAR Hydro ID: Vivekanandan et al., (1999)) to identify hydrometeor types (rain, hail, and snow), insects, and ground targets. The hydrometeor classification algorithm to be used with the UND radar will be verified and improved using in situ observations from the research aircraft.

9. References

- Bringi, V. N. and V. Chandraseker, 2001: *Polarimetric Doppler Weather Radar: Principles and Applications*. Cambridge University Press, United Kingdom, 636 pp.
- Delene, D. J., Airborne Data Processing and Analysis Software Package, *Earth Science Informatics*, **4**(1), 29-44, 2011, URL: <http://dx.doi.org/10.1007/s12145-010-0061-4>, DOI: 10.1007/s12145-010-0061-4.
- Delene, D. J. and T. Deshler, Calibration of a Photometric Cloud Condensation Nucleus Counter Designed for Deployment on a Balloon Package, *Journal of Atmospheric and Oceanic Technology*, **17**, 459-467, 2000.
- Delene, D, C. Grainger, P. Kucera, D. Langerud, M. Hamm, R. Mitchell, and C. Kruse, 2011: The second polarimetric cloud analysis and seeding test. *J. Wxmod*, **43**, 14-28.
- Dixon, M., and G. Wiener, 1993: TITAN Thunderstorm identification, tracking, and nowcasting – a radar-based methodology. *J. Atmos. Oceanic Tech.*, **10**, 785-797.
- Kucera, P. A., A. Theisen, and D. Langerud, 2008: Polarimetric Cloud Analysis and Seeding Test (POLCAST). *J. Wxmod.*, **40**, 64-76.
- Vivekanandan, J., D. S. Zrnic, S. M. Ellis, R. Oye, A. V. Ryzhkov, and J. Straka, 1999: Cloud Microphysics Retrieval Using S-Band Dual-Polarization Radar Measurements. *Bull. Amer. Meteor. Soc.*, **80**, 381-388.

10. Contact List

Conference Call 6 Person Phone Number Bridge:

(701) 777-0967

Access Code: 528784

Radio Frequencies:

Main – 122.825

Backup - 122.925

Aircraft Tail Number - N98585

UND POLCAST4 Wiki Page:

<http://atmoswiki.aero.und.edu/atmos/citation/field/northdakota2012/home>

NDARB Forecasting:

<http://www.swc.state.nd.us/4dlink6/4dcgi/Meteorology%20Staff/OtherForecast/Atmospheric%20Resources>

UND Surface Aerosol Log:

<http://atmoswiki.aero.und.edu/atmos/citation/field/northdakota2012/documentationsurface2012log>

Table 7: University of North Dakota (UND) contact list.

Name	Phone	Position/Purpose	Email
Chris Theisen	(701) 777-6139 (Office) (701) 610-1357 (Cell)	Radar Research Meteorologist	ctheisen@aero.und.edu
Computer Lab (Clifford Hall 422)	(701) 777-2392	Briefing Room	NA
David Delene	(701) 777-4847 (Office) (218) 893-2655 (Home) (507) 533-5363 (Cell)	UND Principal Investigator	delene@aero.und.edu
Gretchen Mullendore	(701) 777-4707	UND Lead WRF Modeling	gretchen@atmos.und.edu

Jonathan Sepulveda	(262) 620-1230 (Cell)	Backup UND Flares	Jon.sepulveda1522@gmail.com
Mariusz Starzec	(860) 462-2046	Student (Modeling/Radar)	Mariusz.starzec@my.und.edu
Nicole Bart	(218) 414-0018 (Cell)	Student (Aircraft/Surface)	Nicole.Bart@my.und.edu
Operations Center	(701) 777-4599	Radar/Radio Control Room	NA
Pavle Kirilov	(701) 777-3244	Radar Engineer	pkirilov@atmos.und.edu
Phondie Simelane	(701) 317-5369 (Cell)	Student (Surface/Aircraft)	Phondie.simelane@my.und.edu
Timm Uhlmann	(320) 288-6416 (Cell)	Student (Radar/Satellite)	Timm.uhlmann@my.und.edu
Wayne Schindler	(701) 777-7901 (Office) (218) 791-2460 (Cell)	Primary UND Flares	wschindler@aero.und.edu

Table 8: National Center for Atmospheric Research (NCAR) contact list.

Name	Position/Purpose	Phone	Email
Paul Kucera	NCAR Principal Investigator	(303) 497-2807 (Office) (720) 381-7816 (Cell)	pkucera@ucar.edu

Table 9: Weather Modification Inc. (WMI) contact list.

Name	Position/Purpose	Phone	Email
Dennis Afseth	Lead Instrument Technician	(701) 235-5500 (Office) (701) 799-5461 (Cell)	dafseth@weathermod.com
Hans Ahlness	Lead Pilot	(701) 235-5500 (Office) (701) 371-4064 (Cell)	hans@weathermod.com
Kelly Bosch	Avionics	(701) 235-5500 (Office)	kbosch@fargojet.com
Todd Schulz	Instrument Technician	(701) 235-5500 (Office)	Tm_schulz@yahoo.com

Table 10: North Dakota Atmospheric Resource Board contact list.

Name	Position/Purpose	Phone	Email
Dan Brothers	Lead Forecaster	(701) 328 2788 (Office) (701) 214 0040 (Cell)	dabrothers@nd.gov
Darin Langerud	Project Manager	(701) 328-2788 (Office) (701) 400-5101 (Cell)	dlangerud@nd.gov